

MODEL

EMY3109Z
embraco
Nidec

APPROVALS



ENGINEERING CODE
 170AA77



APPROVED REFRIGERANT
 R-134a



POWER SUPPLY
 220-240 V 50 Hz

STANDARD CONDITIONS
 ASHRAE

APPLICATION
 L/MBP

COOLING CAPACITY
 102 W (LBP)

EFFICIENCY
 1.26 W/W (LBP)

MOTOR TYPE
 RSIR

STARTING TORQUE
 LST

DATA
General Data

Type	Hermetic reciprocating
Technology Type	On-Off
Displacement	3.97 cm ³
Compressor Cooling	Static/NotControlled/220
Expansion Device	Capillary Tube
Horse Power	1/10 hp
Max Condensing Pressure Operating	13.92 bar
Max Condensing Pressure Peak	15.62 bar
Power Supply	220-240 V 50 Hz
Evaporating Temperature Range	-35 °C to 5 °C

Electrical Data

Motor type	RSIR
Starting Torque	LST
Start Winding Resistance	20.2 Ω at 25° C
Run Winding Resistance	30.8 Ω at 25° C

Mechanical Data

Maximum Recommended Refrigerant Charge	250 g
Oil Charge	150 ml
Oil Type Configuration	ESTER
Oil Type Viscosity	ISO10
Pressurization	Light vacuum
Weight	7.3 Kg
Free Internal Volume	1.5 L

Electrical Components

	Description
Starting Device	PTC V230
Motor Protection	AE64FS

External Characteristics

Base Plate	European	
Tray Holder	Yes	
Height	166 mm	
Connector	Internal Diameter	Shape
Suction	6.1 mm	Slanted 42°/Copper
Discharge	4.94 mm	Straight/Copper
Process	6.1 mm	Slanted 46°/Copper

PERFORMANCE

Rated Points

Condensing Temperature	Evaporating Temperature	Cooling Capacity	Power Consumption	Current	Gas Flow Rate	Efficiency
54.40°C	-23.30°C	102 W	81 W	0.57 A	2.01 kg/h	1.26 W/W

Test Condition: ASHRAELBP32, Static/NotControlled/220, Return Gas 32.2°C, Evaporation -23.30°C, Condensing 54.40°C, Ambient 32.2°C, Liquid 32.2°C, Subcooling 22.2K. Data in accordance to EN

12900:2013 and AHRI 540:2015 polynomial equation and uncertainty guidance.

Performance Curve Data

Condensing Temperature 35°C

Evaporating Temperature °C	Cooling Capacity W	Power W	Current A	Gas Flow Rate kg/h	Efficiency W/W
-35	60	54	0.5	1.16	1.13
-30	82	63	0.52	1.59	1.29
-25	111	73	0.54	2.15	1.51
-20	147	84	0.56	2.85	1.76
-15	190	94	0.6	3.71	2.03
-10	241	104	0.64	4.72	2.31
-5	301	115	0.7	5.91	2.61
0	369	126	0.77	7.28	2.92
5	445	137	0.85	8.83	3.24

Test Condition: ASHRAELBP32, Static/NotControlled/220, Return Gas 32.2°C, Ambient 32.2°C, Liquid 32.2°C. Data in accordance to EN 12900:2013 and AHRI 540:2015 polynomial equation and uncertainty guidance.

Condensing Temperature 45°C

Evaporating Temperature °C	Cooling Capacity W	Power W	Current A	Gas Flow Rate kg/h	Efficiency W/W
-35	55	52	0.51	1.06	1.04
-30	75	63	0.53	1.46	1.19
-25	103	75	0.55	1.99	1.37
-20	137	87	0.58	2.66	1.57
-15	178	101	0.61	3.48	1.78
-10	228	115	0.66	4.46	1.99
-5	285	130	0.72	5.61	2.2
0	351	146	0.79	6.93	2.41
5	426	163	0.88	8.44	2.61

Test Condition: ASHRAELBP32, Static/NotControlled/220, Return Gas 32.2°C, Ambient 32.2°C, Liquid 32.2°C. Data in accordance to EN 12900:2013 and AHRI 540:2015 polynomial equation and uncertainty guidance.

Condensing Temperature 55°C

Evaporating Temperature °C	Cooling Capacity W	Power W	Current A	Gas Flow Rate kg/h	Efficiency W/W
-25	92	75	0.56	1.78	1.22
-20	124	89	0.6	2.41	1.39
-15	164	105	0.64	3.19	1.57
-10	211	122	0.7	4.13	1.73
-5	266	140	0.77	5.24	1.9
0	330	161	0.85	6.51	2.05
5	402	183	0.95	7.97	2.2

Test Condition: ASHRAELBP32, Static/NotControlled/220, Return Gas 32.2°C, Ambient 32.2°C, Liquid 32.2°C. Data in accordance to EN 12900:2013 and AHRI 540:2015 polynomial equation and uncertainty guidance.

Operating Envelope

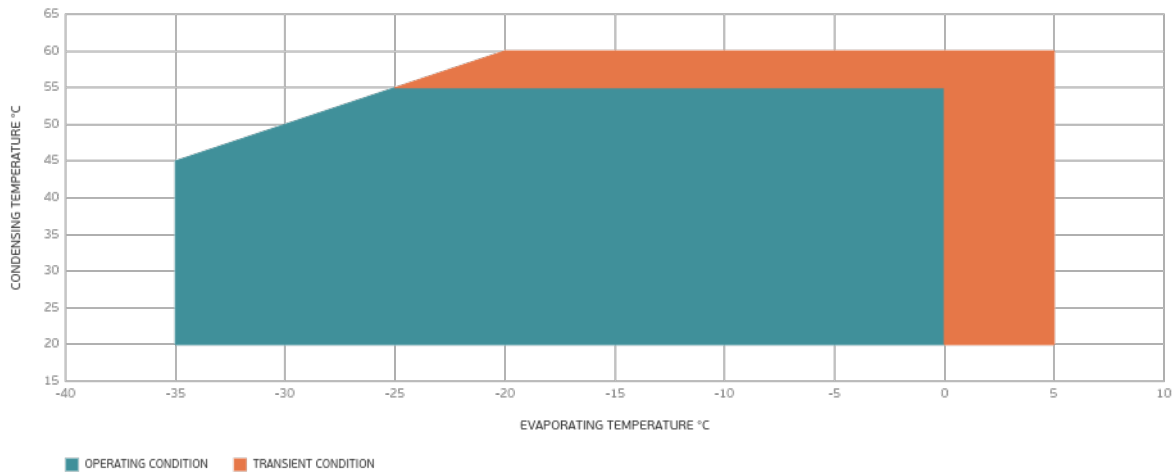

External Dimensions

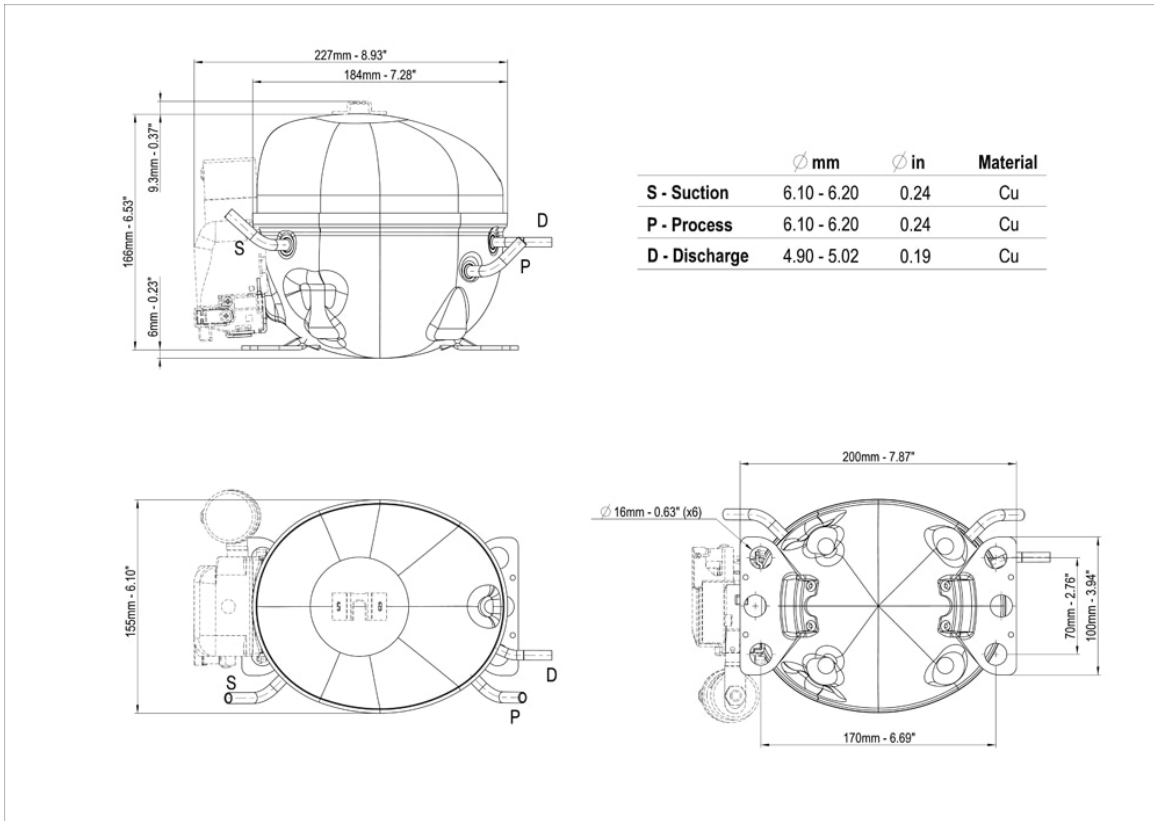

Wiring Diagram

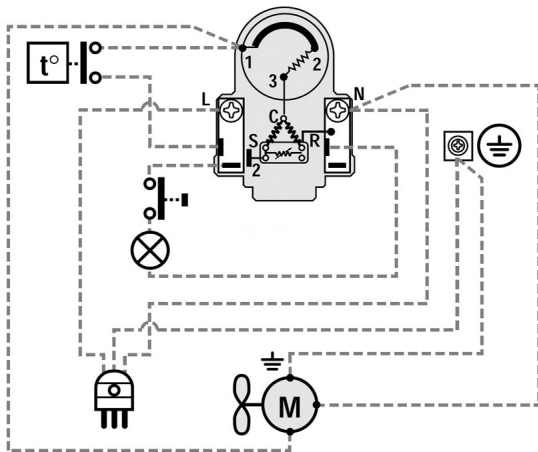

Assembly Instructions

